



# SCHLUMBOHM Sterilizer SHS.1.1

- ergonomic and future-proof
- fast and fully automatic
- small space requirement (compact)

## SHS.1.1 SERIES

### YOUR ADVANTAGES

- very compact, fits through any door
- flexible installation (unit on rollers)
- autom. door opening, does not require compressed air
- economical due to reduced operating costs
- easy documentation via USB stick
- durable due to electropolished chamber
- user-friendly menu navigation

### PERFORMANCE FEATURES

#### **Display:**

- large 7" color touchscreen

#### **Construction:**

- optimal loading height
- single door / double door version
- integrated steam generator

#### **Control system:**

- networkable control

#### **Documentation:**

- USB stick (standard)
- integrated printer (optional)

#### **External dimensions:**

- Width 650 mm
- Height 1.700 mm
- Depth 890 mm

#### **Capacity:**

- 1 StU / 76 liters

Please let yourself professionally from ours Product specialists advise.



SCHLUMBOHM Medizin-Labor-Technologie-Hamburg GmbH  
Grenzkehre 1 | 21079 Hamburg  
Phone: +49 (0) 40 769150 - 0 | Fax: +49 (0) 40 769150 - 26  
www.schlumbohm-medlab.com | info@schlumbohm-medlab.com

Request your individual offer without obligation.





## STEAM STERILIZER SCHLUMBOHM SHS.1.1 (1StU)

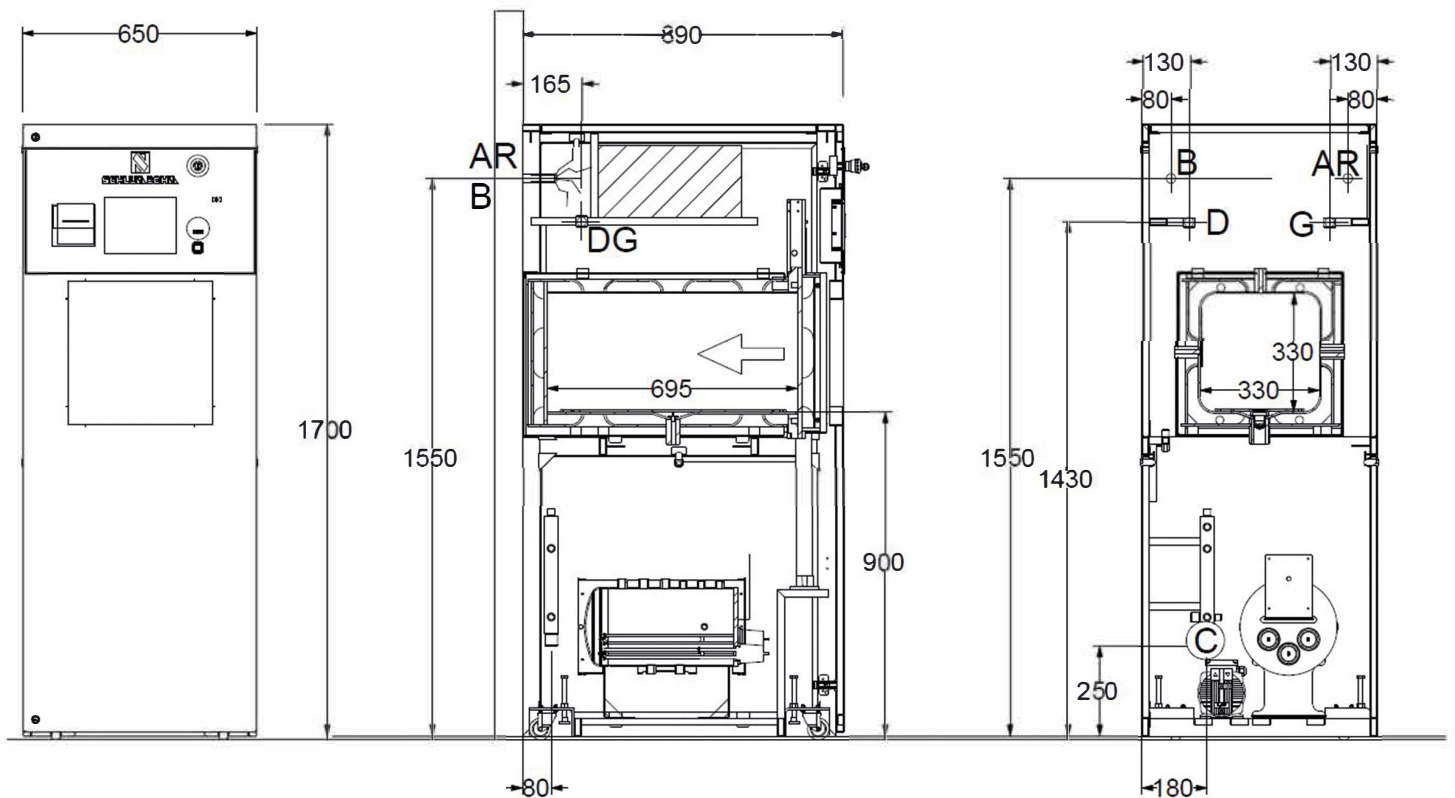

We are looking forward to your call +49 40 7691500.  
Sales-Mail [vertrieb@schlumbohm-medlab.com](mailto:vertrieb@schlumbohm-medlab.com).



SCHLUMBOHM Medizin-Labor-Technologie-Hamburg GmbH  
Grenzkehre 1 | 21079 Hamburg  
Phone: +49 (0) 40 769150 - 0 | Fax: +49 (0) 40 769150 - 26  
[www.schlumbohm-medlab.com](http://www.schlumbohm-medlab.com) | [info@schlumbohm-medlab.com](mailto:info@schlumbohm-medlab.com)

Request your individual offer without obligation.

